

FOLDING DOOR CONFIGURATIONS

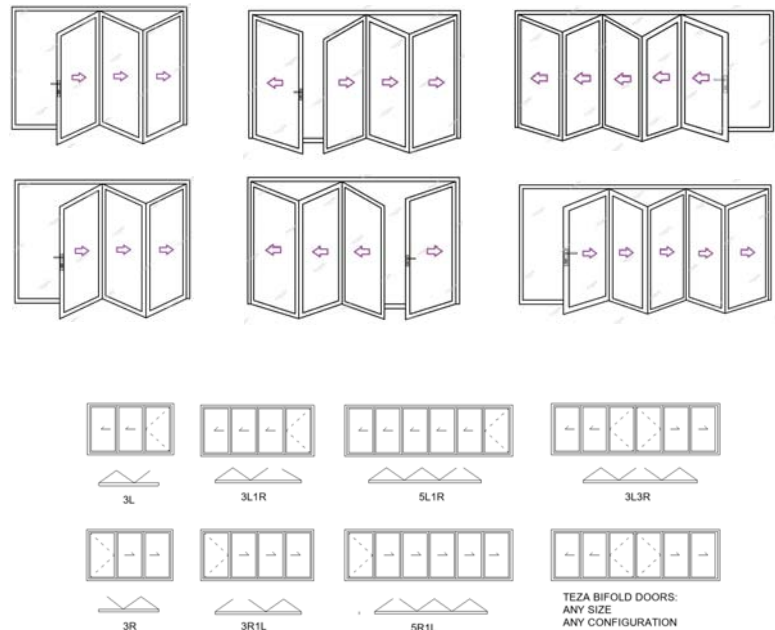

60 SERIES FOLDING DOOR DETAILS

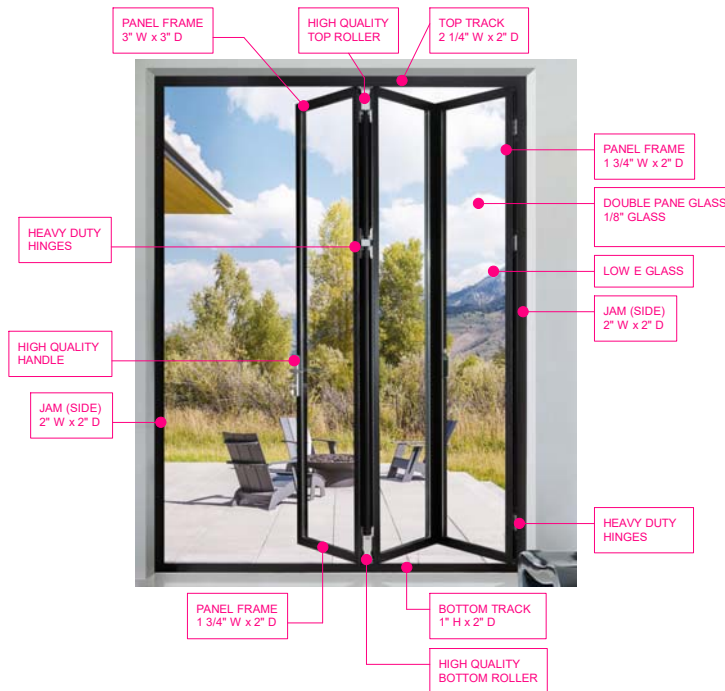

TITLE 24

TEZA BIFOLD PATIO DOORS ARE IN COMPLIANCE WITH BUILDING CODE (TITLE 24) THAT HAS BEEN TESTED BY 3RD PARTY. CURRENTLY, WE ARE IN THE PROCESS OF GETTING COMPLIANCE WITH NFRC LAB.

SHGC RATING	U- FACTOR
0.26	0.32

GLASS DETAILS

- DOUBLE TEMPERED GLASS
- EACH PANE 5MM GLASS
- E GLASS 100% BLOCK UV
- FILLED WITH ARGON GAS



BIFOLD DOOR HARDWARE



BIFOLD DOOR'S PANEL & GLASS DETAIL

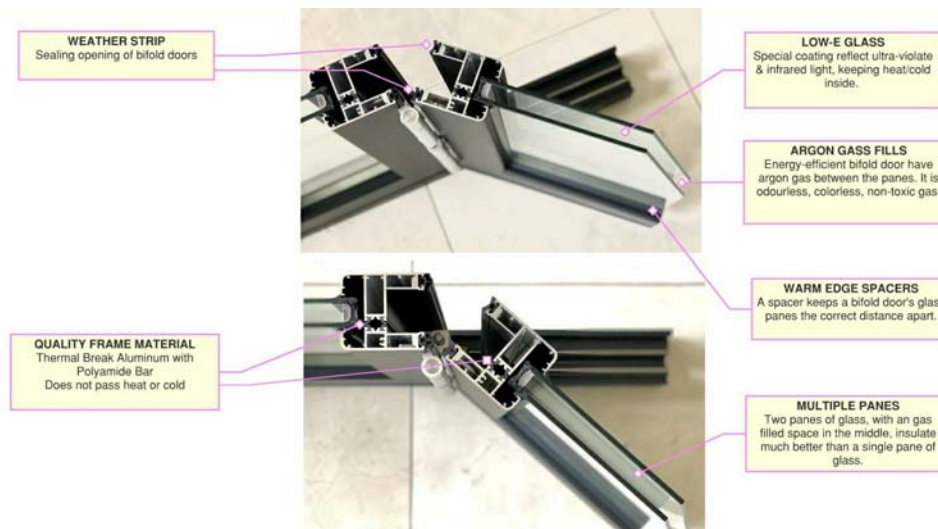

PANEL DETAILS

TEZA 60 SERIES HAS SUPER SLIM FRAME AND SLIM GLASSES WHICH MAKES IT SUPER LIGHT WEIGHT CAN FOLD OR UNFOLD PANELS WITH MINIMUM FORCE.

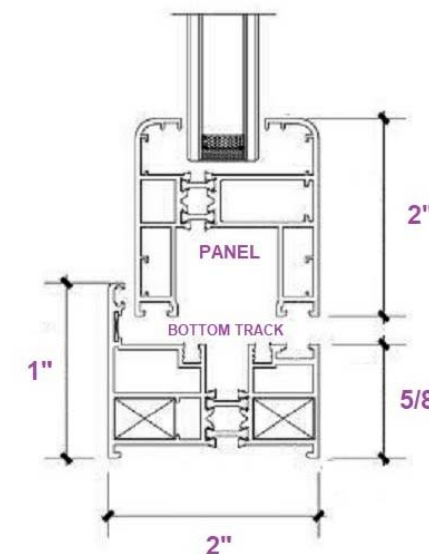

**TEZA DOORS**  
 2235 FIRST ST  
 SIMI VALLEY, CA 93065  
 WWW.TEZADOORS.COM  
 TEZAPRODUCTS@GMAIL.COM  
 CALL: (909) 414-4646

PROJECT

DOOR TYPE

**TEZA 60 SERIES ALUMINUM FOLDING DOOR**

Notes

1. All dimensions are in feet & inches.
2. All dimensions are to be checked on site.
3. Any discrepancy between the architectural drawing and other drawings relevant for construction should be notified before commencement.